

lambert&fils

Studio Presentation

2024

About

Lambert & Fils is a Montréal based design studio exploring the many shapes of light.



Design and Manufacturing Under One Roof

Through our design and production practice, we meditate on the philosophy of *matière première* — materials as a point of origin.

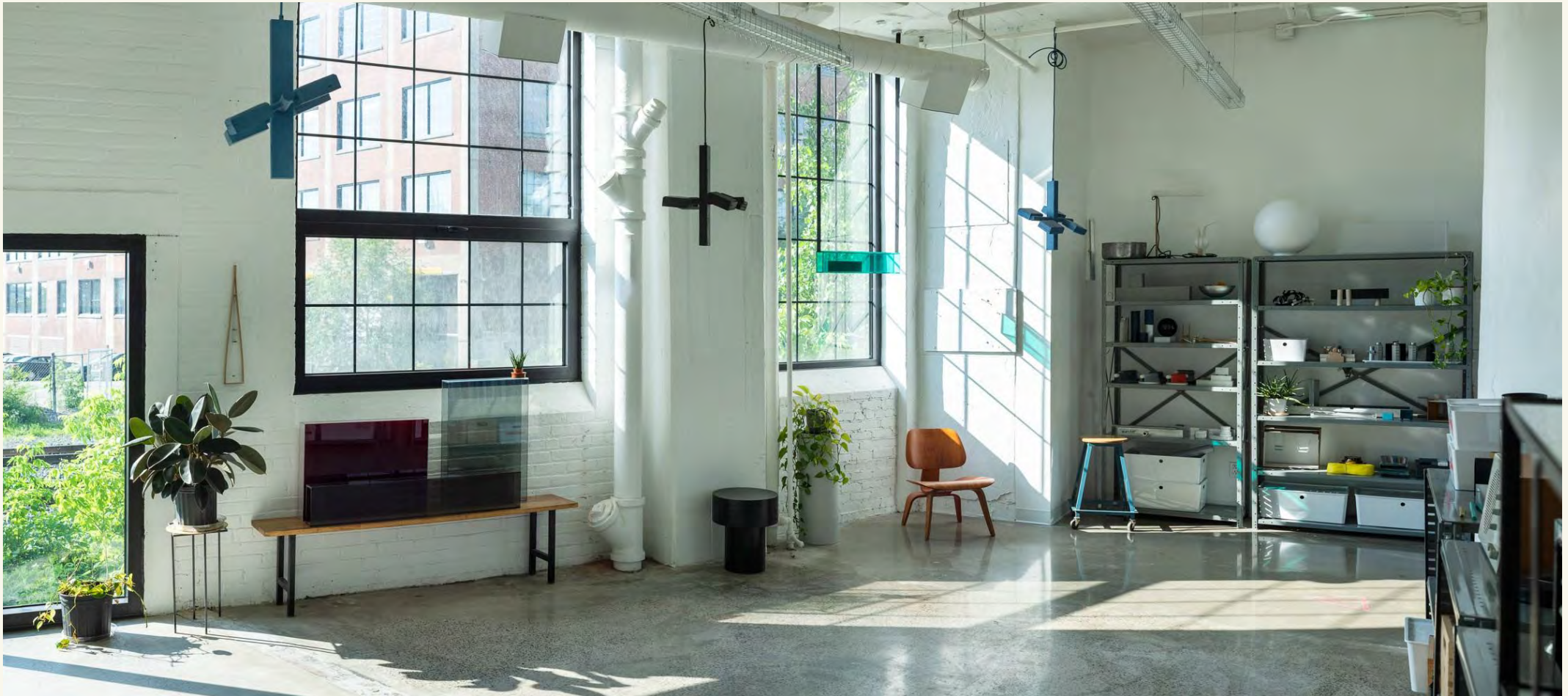

Lambert & Fils Studio, Montréal



Preserving the bond between design and making.

All lighting is handmade from start to finish in our 20,000 square foot atelier.

Handmade design meets high-level production.

Lambert & Fils designs and fabricates bespoke lighting for interiors around the world — straight from our Montreal atelier.





Technology

We believe in the intimacy of light to shape our experiences. Our in-house sustainable LED technology recreates ambient glow and dimming effect of warm incandescence—giving a variety of natural colour temperatures to adapt to different environmental needs.

We develop and fabricate custom LED boards in order to replicate the intimacy and ambience of incandescent lighting.

- LED options at 2700K, 3000k and 3500k
- Quality LED that never flickers
- Many models can be equipped with our custom Dim to warm technology*



New York Showroom



Hudson and Duane Showroom, Tribeca, New York

In 2020, we opened our New York City showroom. Located in the historic Schepp Building, a 19th-century neo-Grec and Romanesque Revival red brick structure, our space stands among the flourishing design district overlooking Tribeca.

The showroom also served as the catalyst for our Atelier collection, a series of extended, theatrical models designed without material constraint.



Hudson and Duane Showroom, Tribeca, New York





Isle





The Collection

A play on illusion and perception that allows lightness to anchor and foundations to rise. Composed of a delicate glass tube resting on solid-stone and aluminum pedestals and suspended in mid-air like a surreal bridge, ISLE is minimal, but never simplistic. The result is striking: blocks of mass both distinct and inextricably linked, like a bridge between two islands.

In keeping with the functional creativity of the studio, ISLE may hold a dreamlike quality, but it isn't merely decorative. Its system is simple yet integrated. Even the suspension wires are a part of the form and design. The lamp remains polymorphous; it is as much a practical object as an object of the imagination.

Created to light a room and reveal the life within it, ISLE was designed to function in spaces large or small. The frosted glass tube diffuses the light evenly on its length and within the space it lives in.

While the single models are a great fit for residential spaces, the clusters are conceived for spacious areas. Composed of multiple modules, these sculptural pieces fill space horizontally in a linear structure or liven an area with volume in a vertical gesture.





Single models

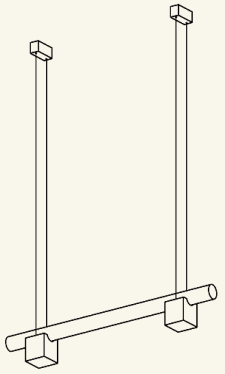

ISLE 01 A

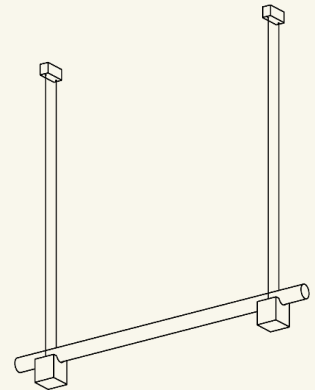

ISLE 02 A

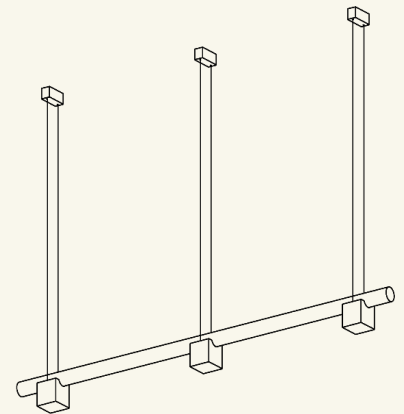

ISLE 03 A

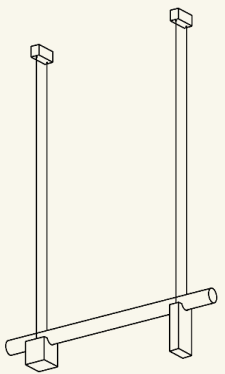

ISLE 01 B

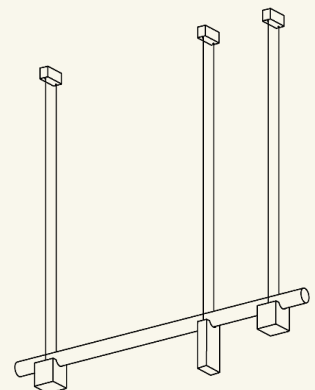

ISLE 02 B

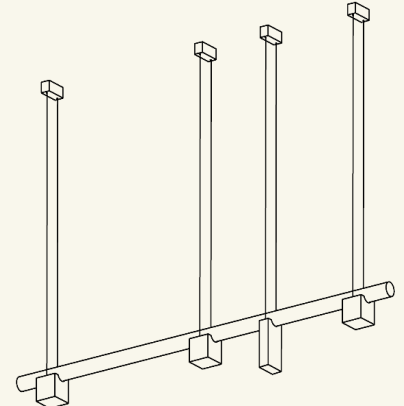

ISLE 03 B

Clusters

ISLE 10
(ISL02A + ISL03A)

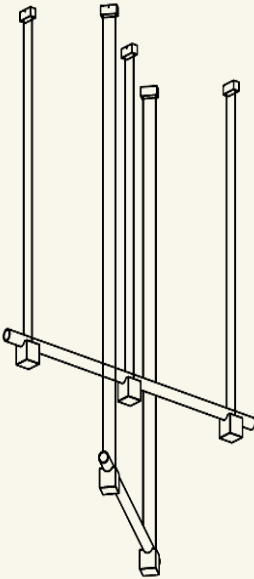

ISLE 11
(ISL02A+ ISL02B)

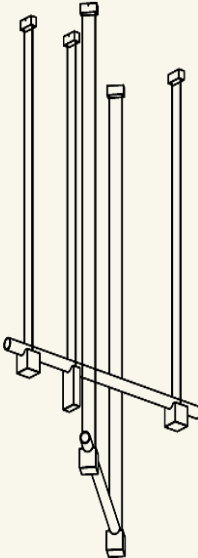

ISLE 12
(ISL01A + ISL02A+ ISL02B)

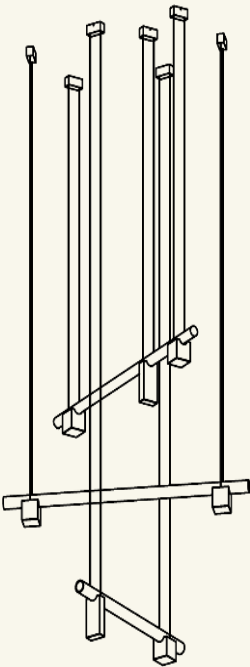

ISLE 13
(ISL01A + ISL02A+ ISL03A)

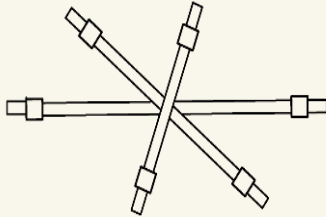
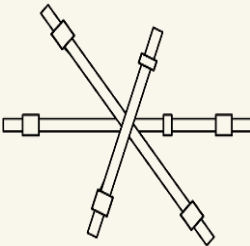
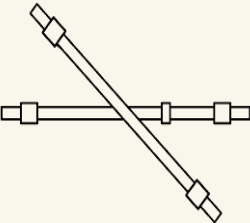
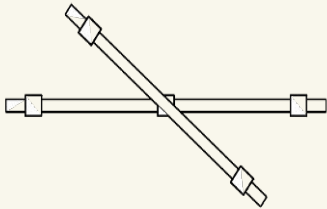
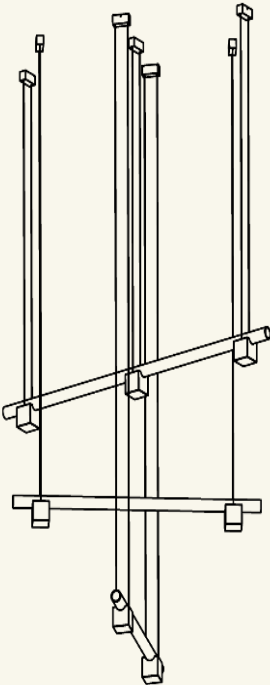

Clusters

ISLE 14
(ISL01B + ISL02B+ ISL03B)

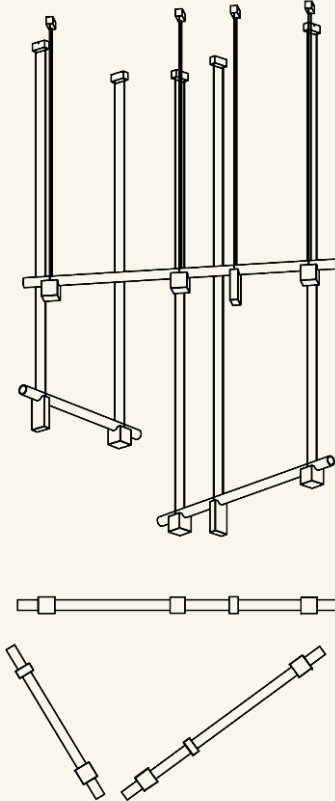

ISLE 15
(ISL01B + ISL03B)

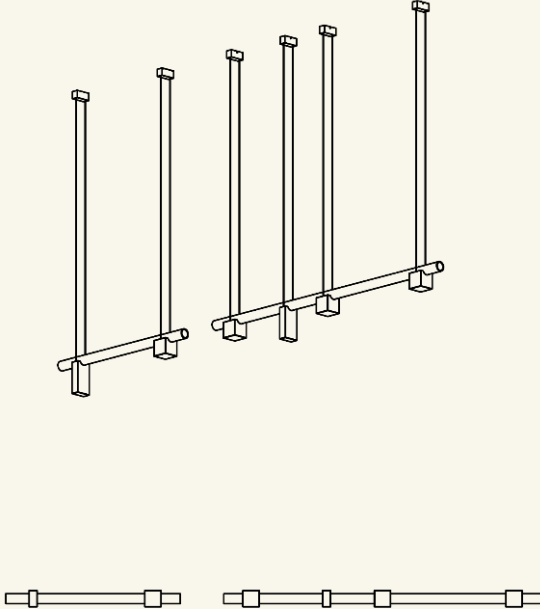

ISLE 16
(ISL01A + ISL02A+ ISL03A)

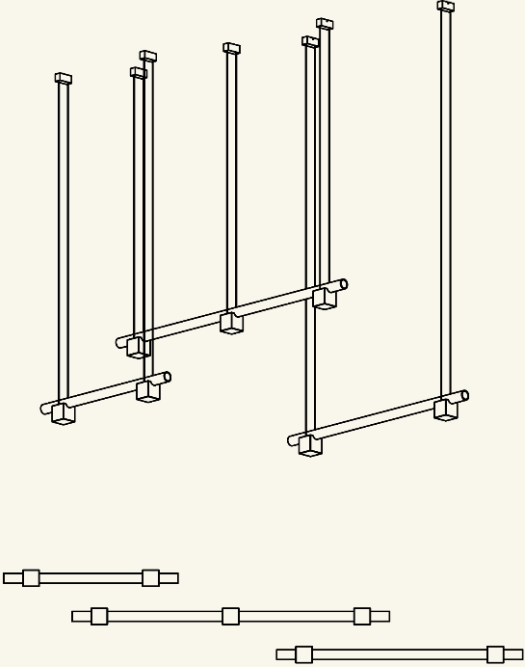



Design Process

The design process between Zoë and the Lambert & Fils team was enriching and natural, a patient and meaningful journey. A winding map and indirect exploration led Zoë to the archetypal tube, then to the stone bases.

“We chose to work with Zoë for the strength of her work throughout the years but also because for me she's a pioneer of the new guard of Canadian designers. She has measured herself against the best international designers which I admire”,
—Samuel Lambert.

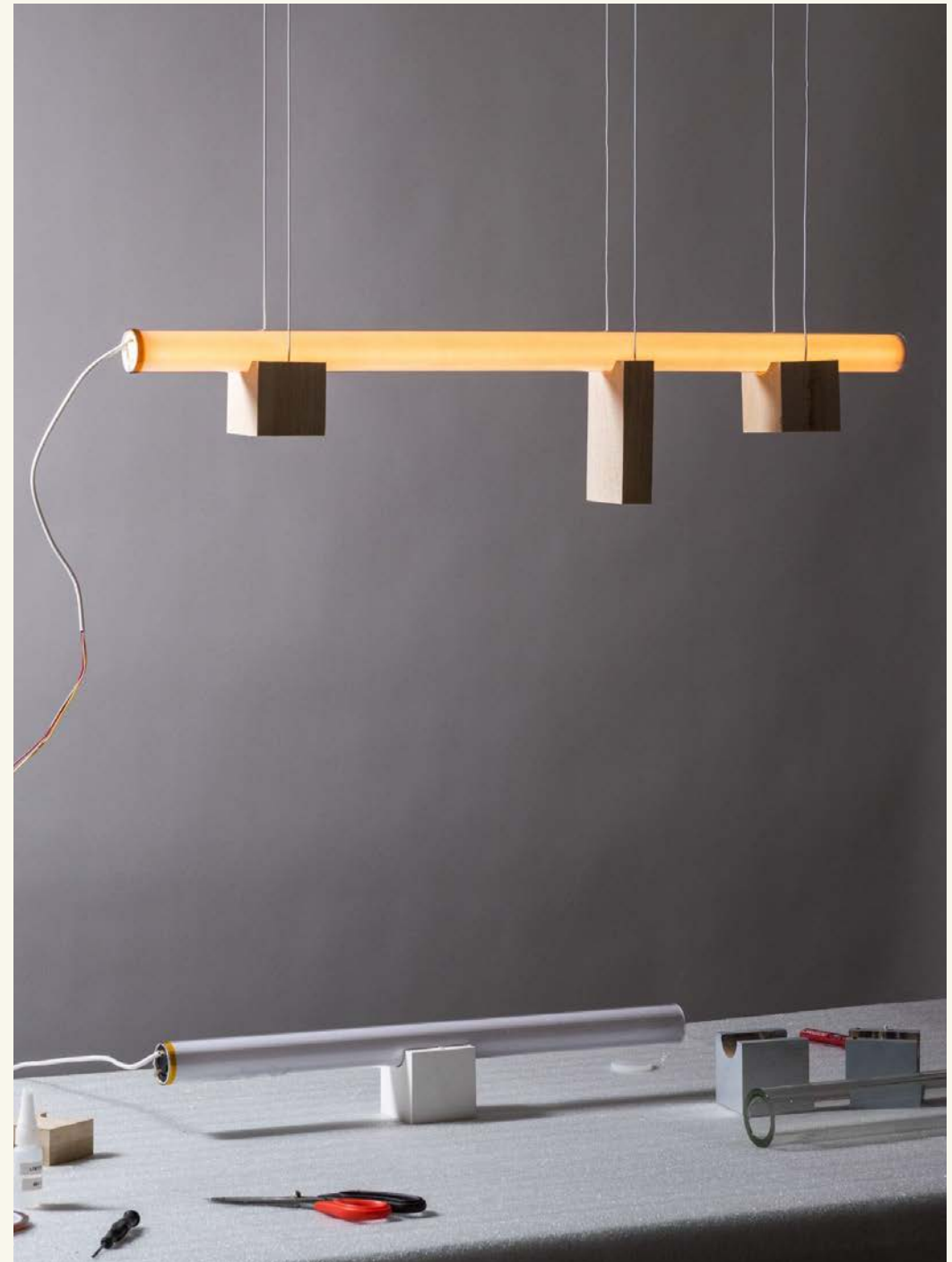





Zoë's practice focuses on the relationship between contrasting materials and textures, and the new forms which can emerge from those relationships. In developing ISLE, light itself became a material, a shape to explore: how to perceive it, how to integrate it, how to transcend it. "*We wanted to work in Zoë's language, without preconceived ideas*", says Samuel Lambert.

Established in New York City, Zoë has developed the collection with the design team at Lambert & Fils through a remote collaboration between Montreal and Manhattan - two islands both strikingly different and complementary, reflecting the collection they have inspired.

zoemowat.com

Materiality

ISLE Collection has many layers of material coexisting within its design. The double layered elongated frosted glass tube enlightens and enhances the texture of the stones it rests on. Currently proposed in an array of deep strong marble square blocks and slabs, contrasting with the vivid polished aluminium of its end cap and block, the full ensemble creates a dynamic and versatile sculptural piece.





Nero Marquina

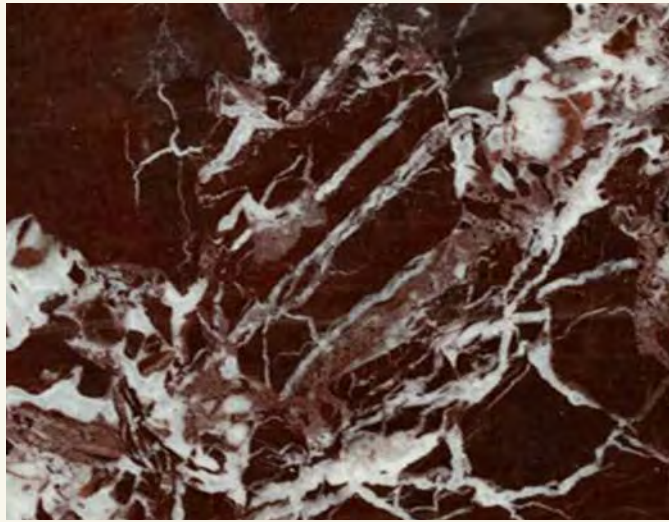

Rosso Levanto

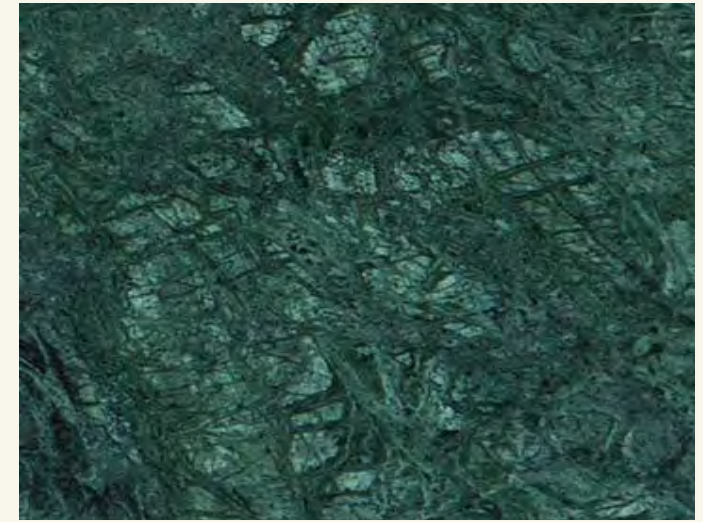

Guatemala Verde



Rosa Portugal

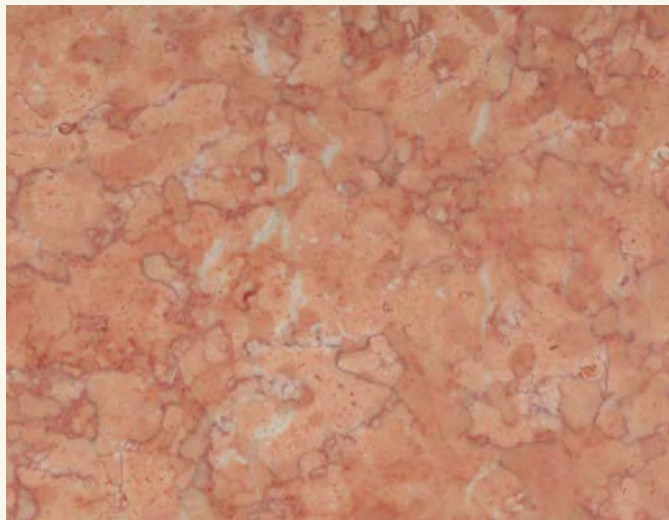

Encarnado Negrais



Polished aluminium

Canopies



Mechanical block

The tube is mainly laid on top of the slabs and blocks without any anchors, although each model is composed of at least one mechanical block that connects its LED panel in the glass tube to the electrical wires hidden in a block.

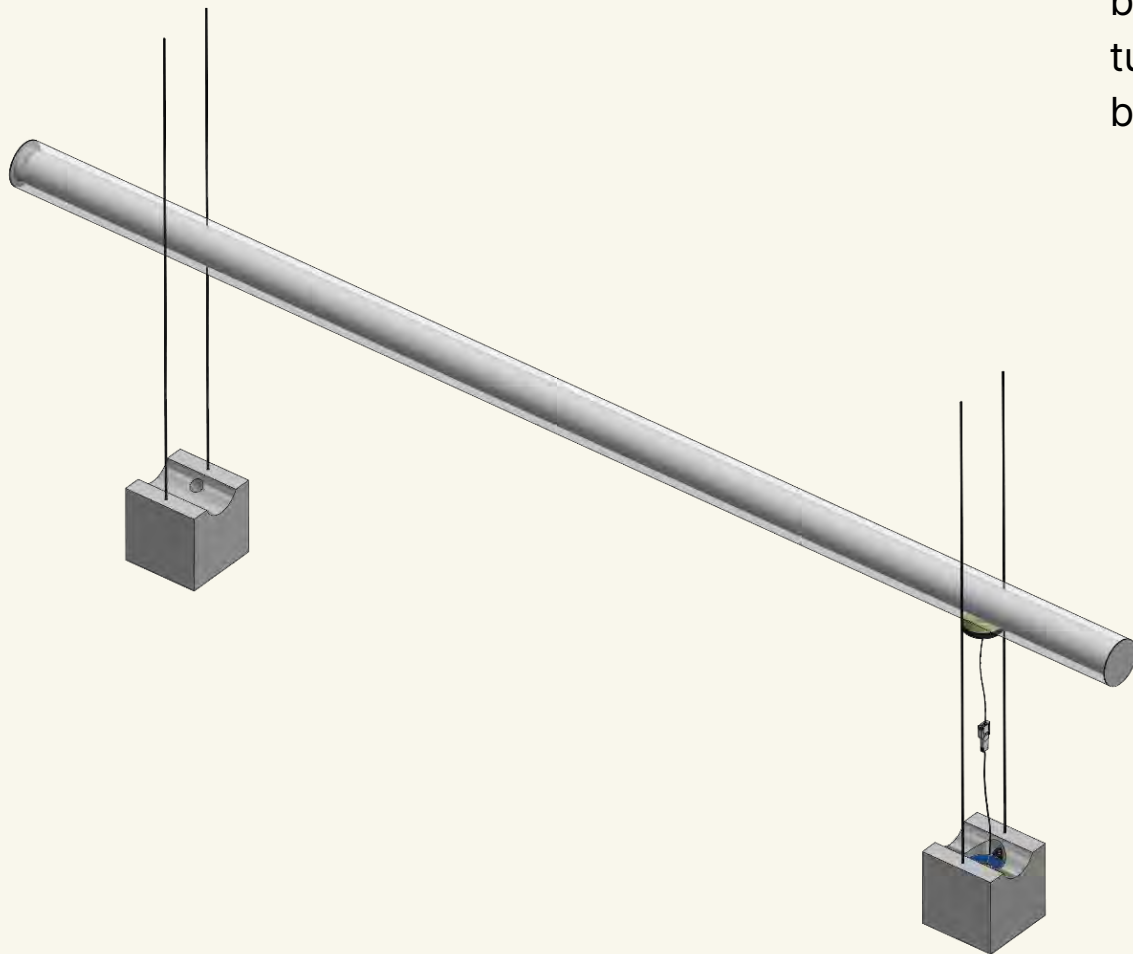



Silo





Named after the historic grain silos lining Montreal's Old Port, the vertical shapes take cues from brutalist architecture, recalling visions of concrete towers, cityscapes or metallic wind instruments.

As compelling when turned off as illuminated, Silo plays with negative space and reflection to magnify its surroundings, all while retaining exquisite simplicity.

The collection reinterprets the age-old extrusion manufacturing process, uniting light and material to spark something larger than their single form.





Caffè Populaire, Milano, 2022



Available in our standard colour gradients, the Silo introduces three new finishes - mirrored polished aluminum, tumbled aluminum, and glossy oxblood. Held up by aircraft wires, Silo is at once weightless and commanding.

The collection also features a new cumin coloured wire - meant to replicate the soft materiality of leather as an unexpected juxtaposition to the Silo's aluminum body.

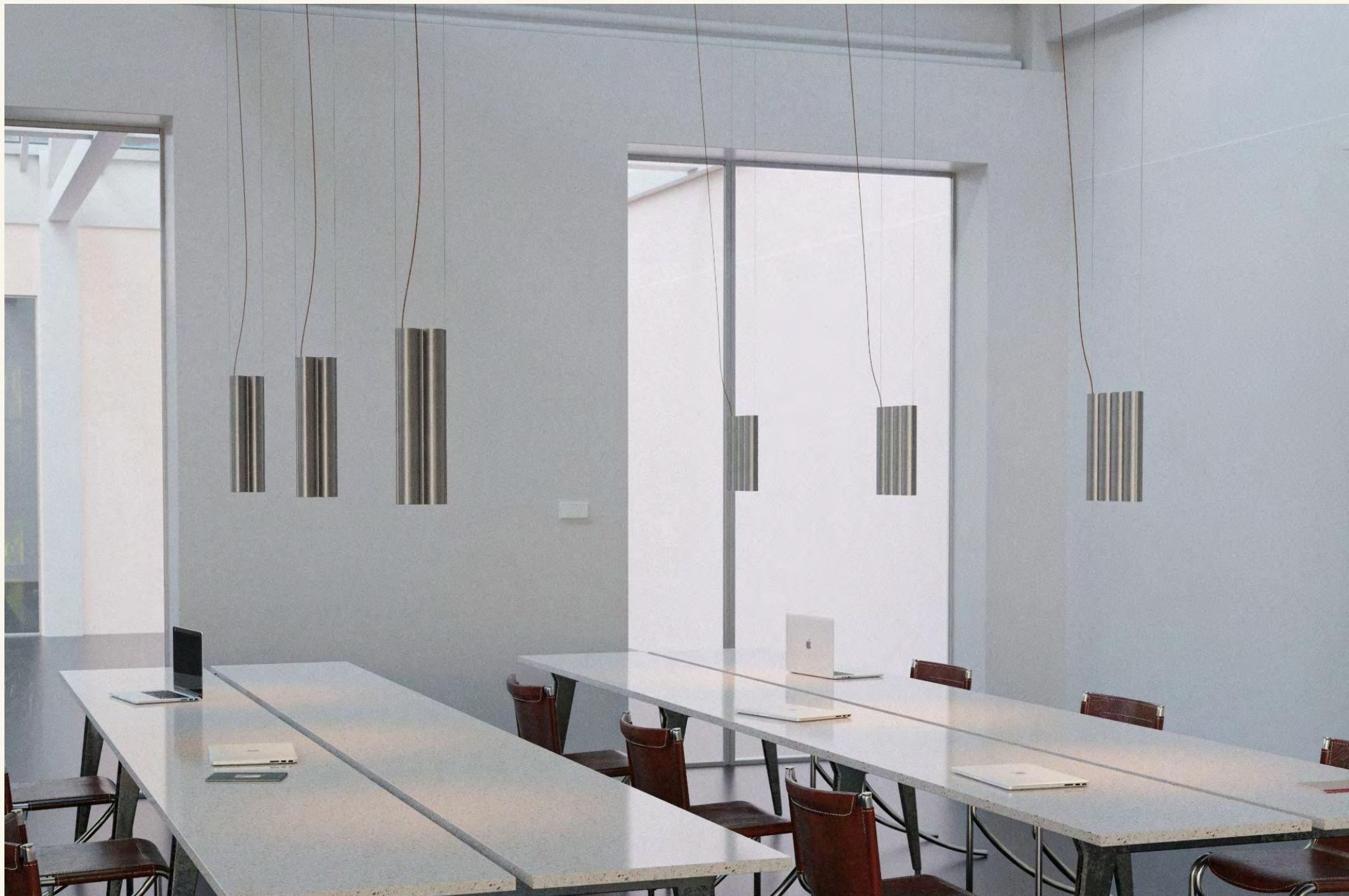



The Suspension Series



SIL2SC
13 × 30 cm
5 × 12 in



SIL2SB
13 × 43 cm
5 × 17 in

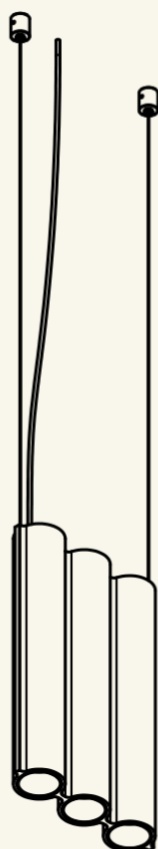

SIL3SA
19 × 30 cm
7.6 × 12 in

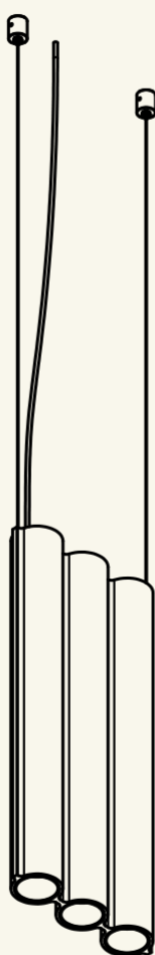

SIL3SB
19 × 43 cm
7.6 × 17 in

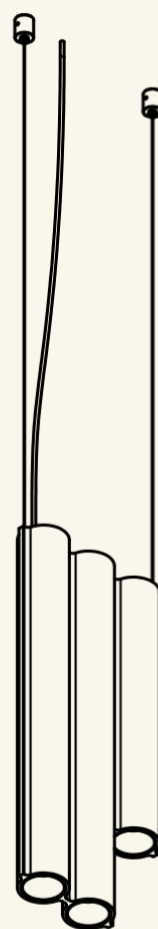

SIL3SD
19 × 43 cm
7.6 × 17 in

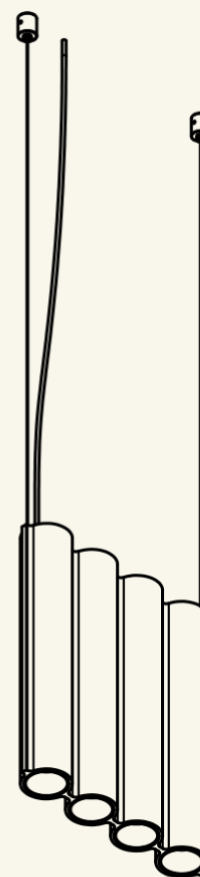

SIL4SA
26 × 30 cm
10 × 12 in

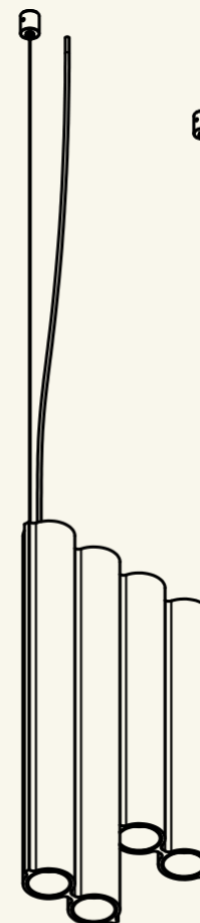

SIL4SE
26 × 43 cm
10 × 17 in

The Cluster Series

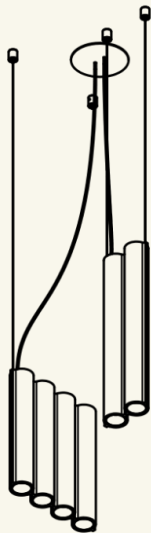

SIL10

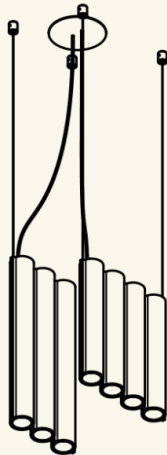

SIL11

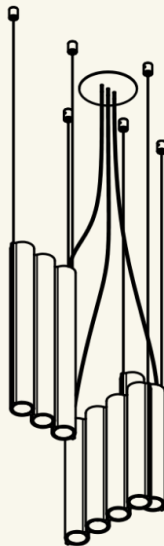

SIL12

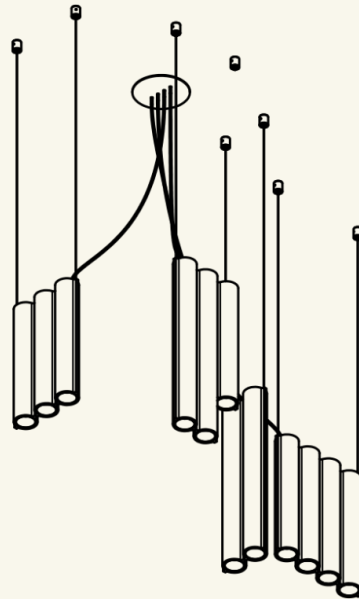

SIL13

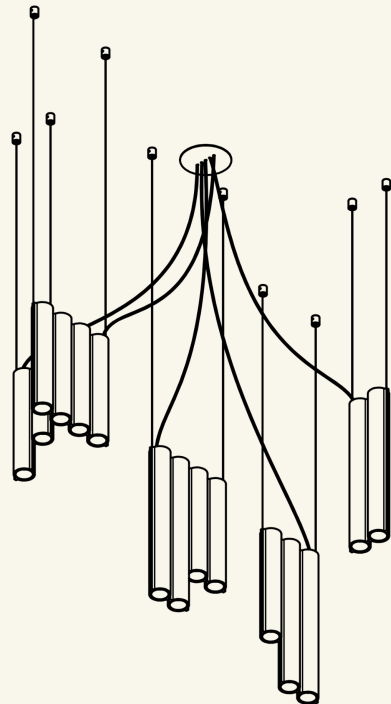

SIL14



Typical assembly

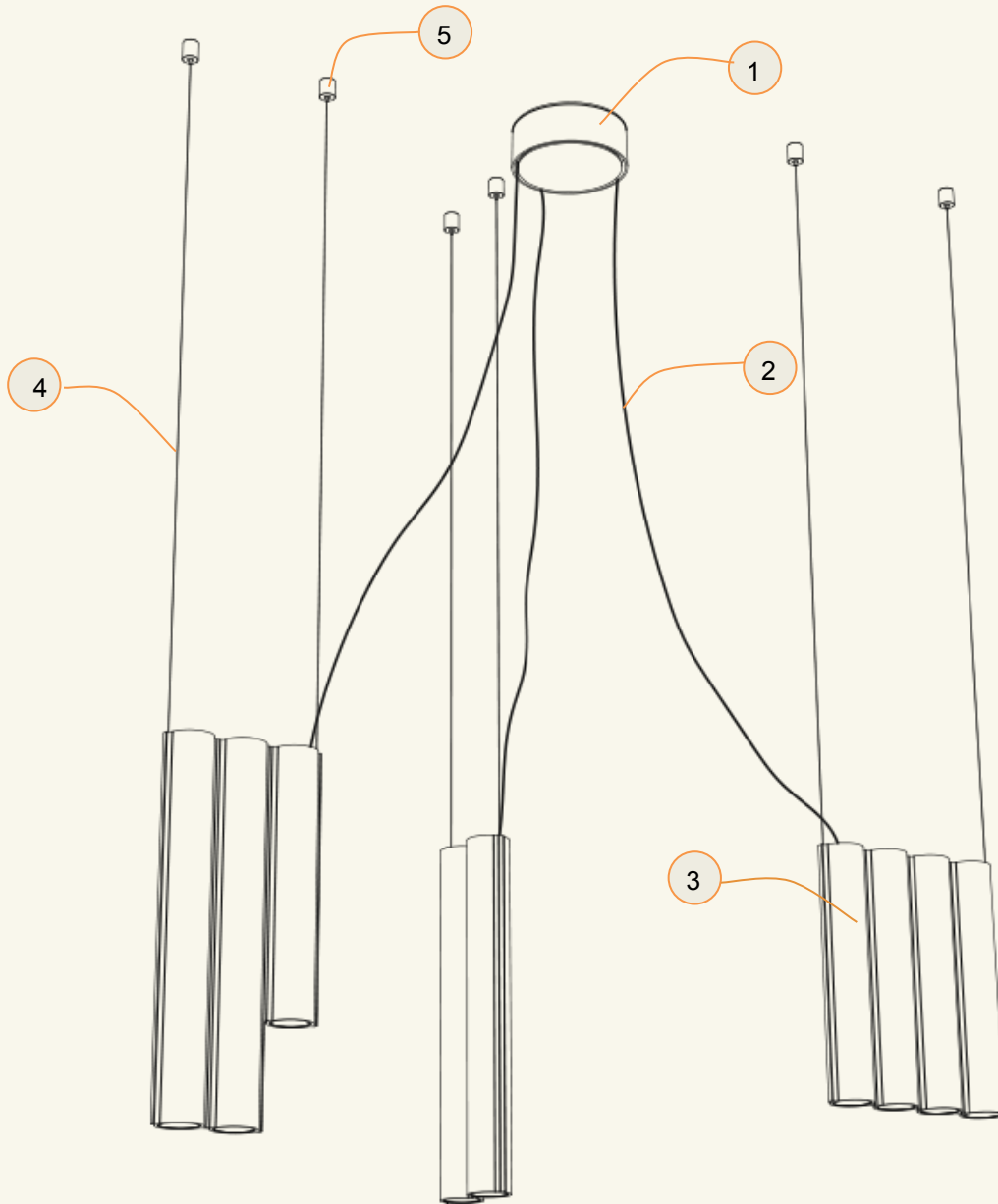

- ① Canopy
- ② Power Cables
- ③ Body
- ④ 1/32" Aircraft Cable
- ⑤ Aircraft Cable Anchor

Canopies

All fixtures come with either white or black canopies. Fixtures can be anchored independently from their canopies.

In the case of Silo 02, the aircraft wires can be affixed to the canopy, as shown below.

For more information, contact order@lambertetfils.com.



Standard white



Standard black



Aircraft wires affixed to canopy (Silo 02)



The Table Models

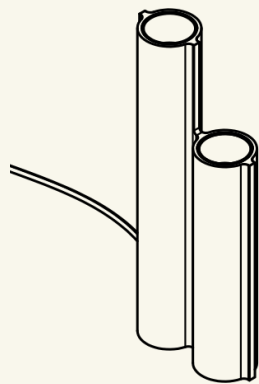

SIL2TF
13 × 30 cm
5 × 12 in

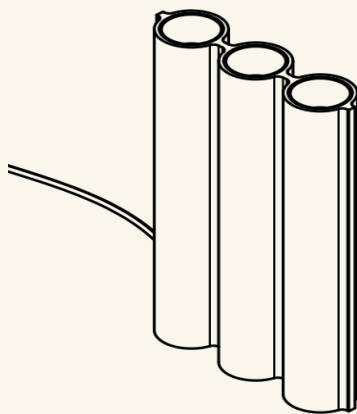

SIL3TA
19 × 30 cm
7.6 × 12 in

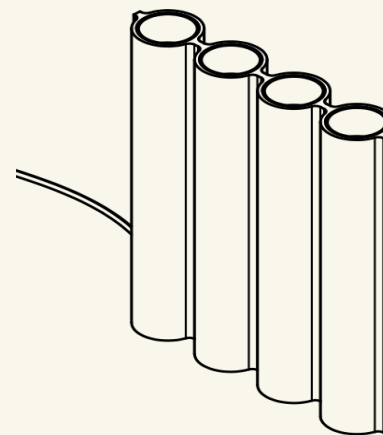

SIL4TA
26 × 30 cm
10 × 12 in

The Wall Models

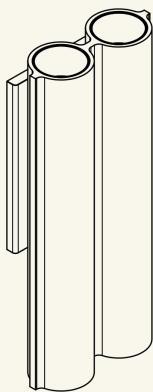

SIL2WA
13 × 30 cm
5 × 12 in

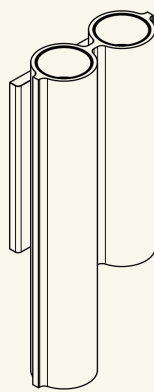

SIL2WC
13 × 30 cm
5 × 12 in

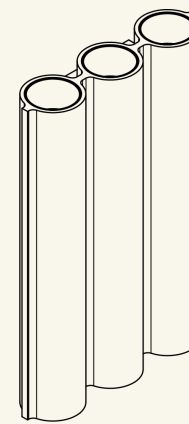

SIL3WA
19 × 30 cm
7.6 × 12 in





Caffè Populaire, 2022

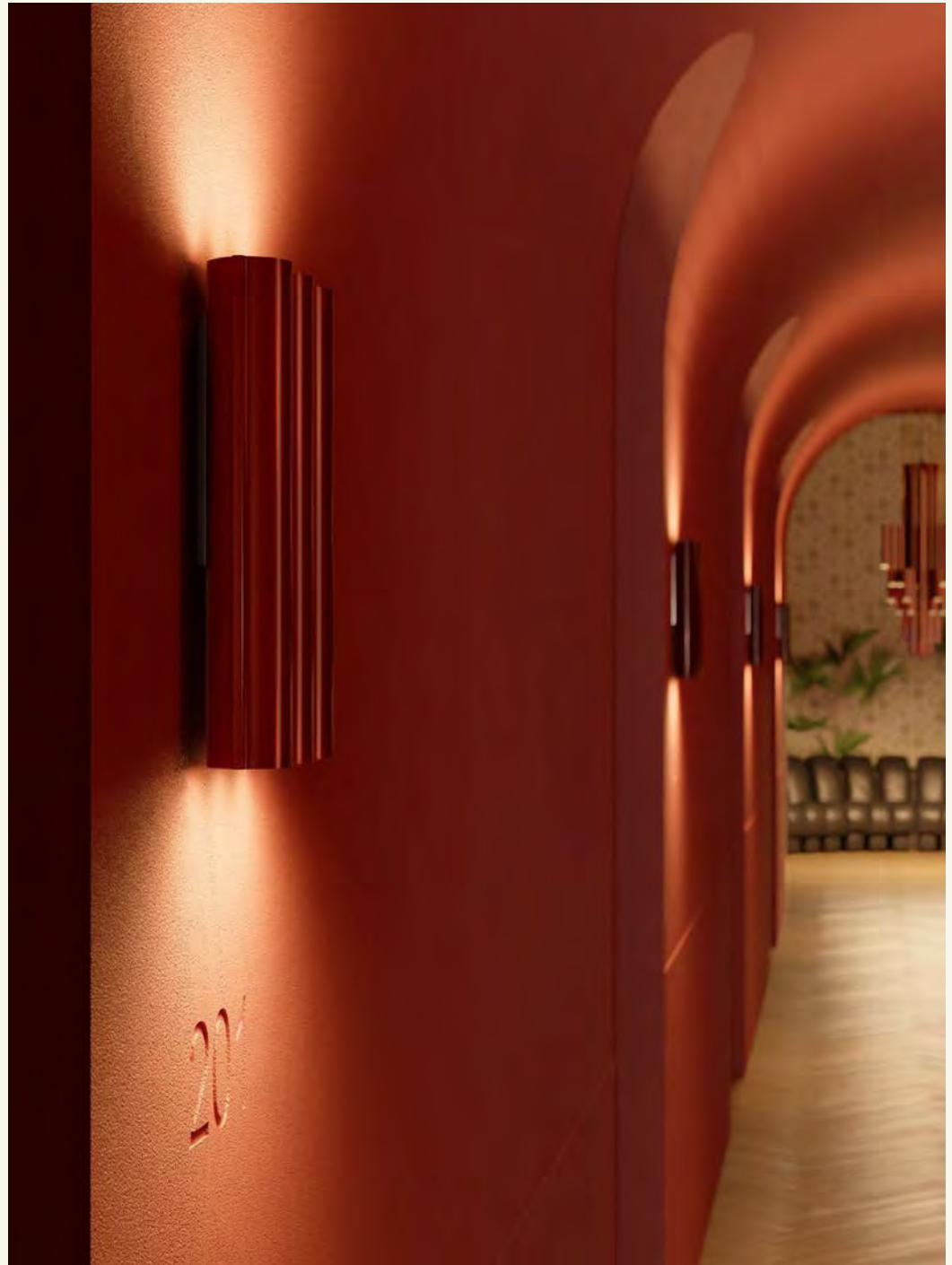
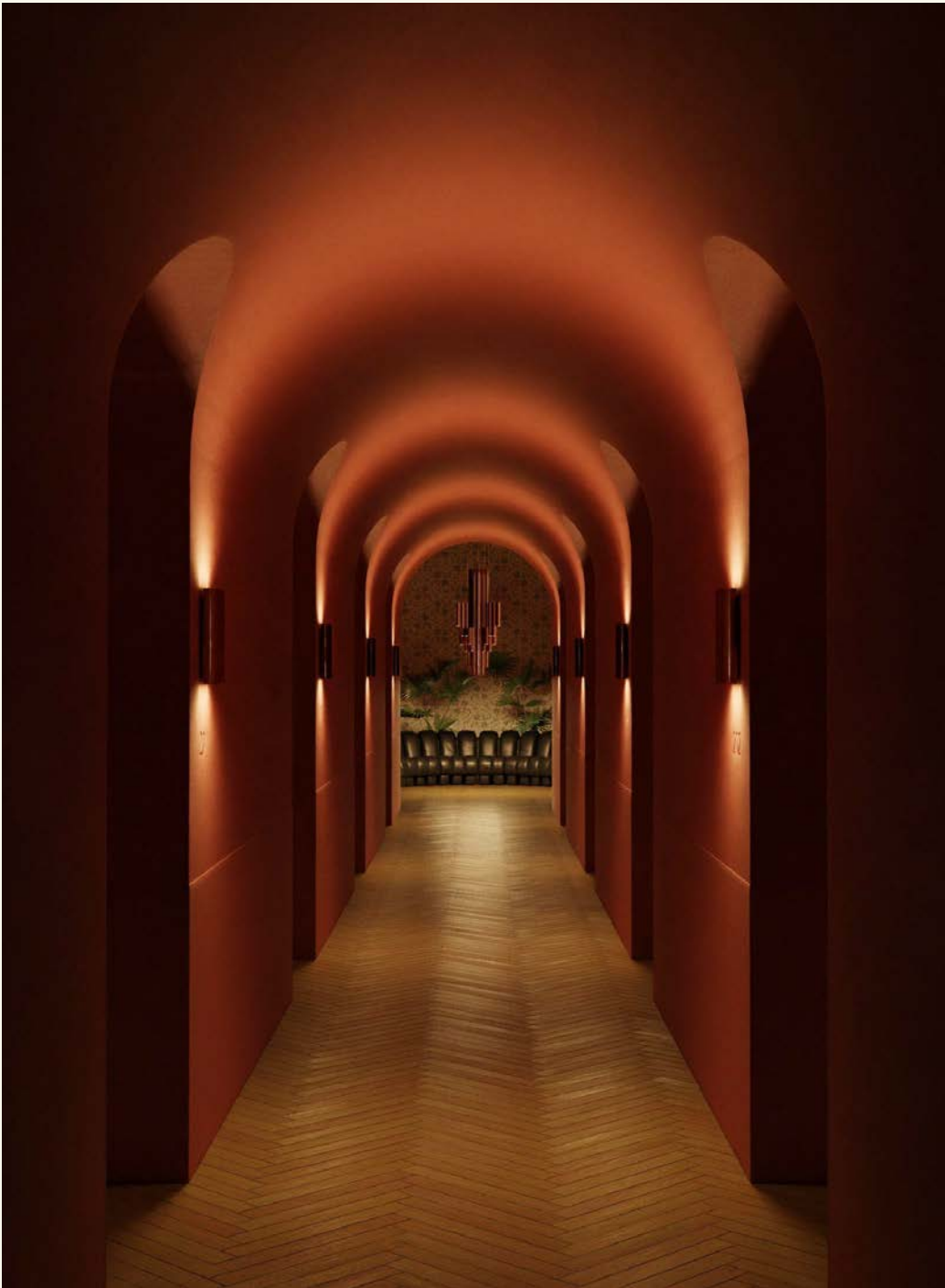

The Floor Models

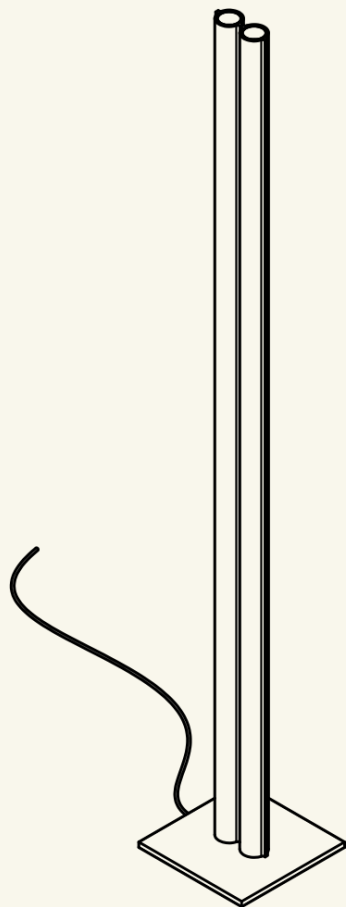

SIL2FG
27 × 183 cm
10.5 × 72 in

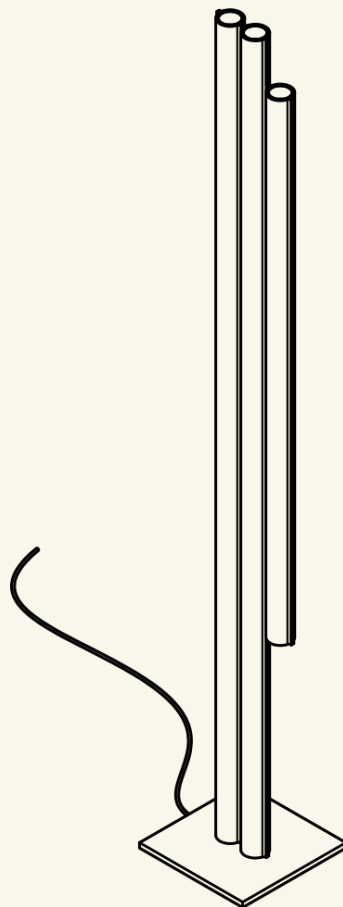

SIL3FH
27 × 183 cm
10.5 × 72 in

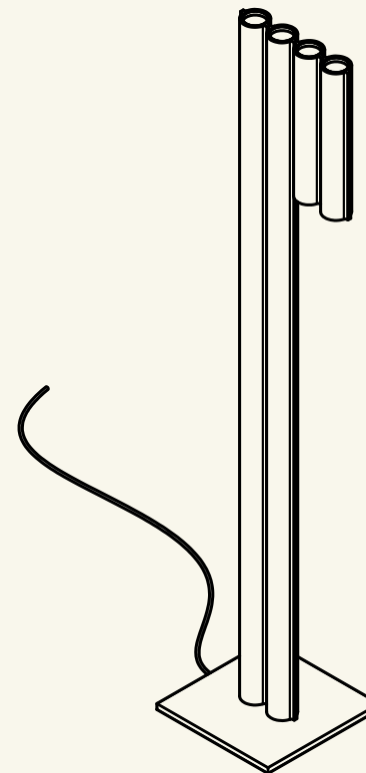

SIL4FI
27 × 141 cm
10.5 × 55.5 in



Technology

We develop and fabricate custom LED boards in order to replicate the intimacy and ambience of incandescent lighting. These quality measurements include:

- Advanced LED that never flickers
- A CRI of 90+, ensuring a colour rendering comparable to natural sunlight

Correlated Colour Temperature (CCT)

Our standard colour chart consists of the below:

- Warm Light 2700K
- Neutral light 3000K
- Dim-to-warm 2700K to 2200K
- Dim-to-warm 3000K to 2200K

All Silo lights come equipped with a specific CCT selection available in 100K increments, from 2200K to 4000K inclusively.

Control

- 0-10V dimming (120V only)
- Phase dimming
- Dali (220-240V only)













Collections

13 artistically designed collections

Great for homes, workplaces, restaurants, hotels, boutiques, and many other spaces globally.



Parc Collection



The Parc Collection is inspired by childhood imagination and the essentiality of homemade forms — created in collaboration with Swiss designer Adrien Rovero.

Evoking the archetype of a flashlight, each lamp in the collection is a playful reminder of time spent in nature, when a simple tube and piece of string could be used to fashion any number of creations.

These makeshift objects, at once naive and functional, harness the unique beauty of peeling something back to its essence.



HERMÈS



Hermès, Switzerland















Caffè Populaire, 2022

Sainte Collection





The Sainte Collection is about the forces that anchor us — a suspension light in dialogue with gravity. Streamlined yet impactful, it reimagines the archetypal rectangle in colourful glass — an elegant mass floating in space and supported by robust nylon ribbon.

Sainte is a collaboration between Lambert & Fils and former lead designer Rachel Bussin. A dance of contrasting materials and an equilibrium of opposing forces.







Caffè Populaire
2019



La Samaritaine, Paris



Lambert & Fils Showroom, New York



AC Hotel, Georgia





Hutchison Collection

Hutchison is the thoughtful study of softs curves and hard lines — a rivalry of vertical and horizontal forces and a play of scale and repetition. Alone, it self-defines as a frank, decorative pendant light. In multiples, it evokes the iconic patterns of Middle Eastern archways and Roman terracotta roofs.







Eberhart furniture, Copenhagen, Denmark







Caffè Populaire Fuorisalone, Milano, 2019

Dorval Collection



Based on SCMP DESIGN OFFICE's original pendant prototype Dorval 01, this collection is layered in history, a subtle interplay between contemporary and vintage industrial design.

Drawing equal inspiration from airport runway lights and the classic Motobecane french moped, the result is a light both confrontational and intriguing—one which poses an immediate invitation to play.

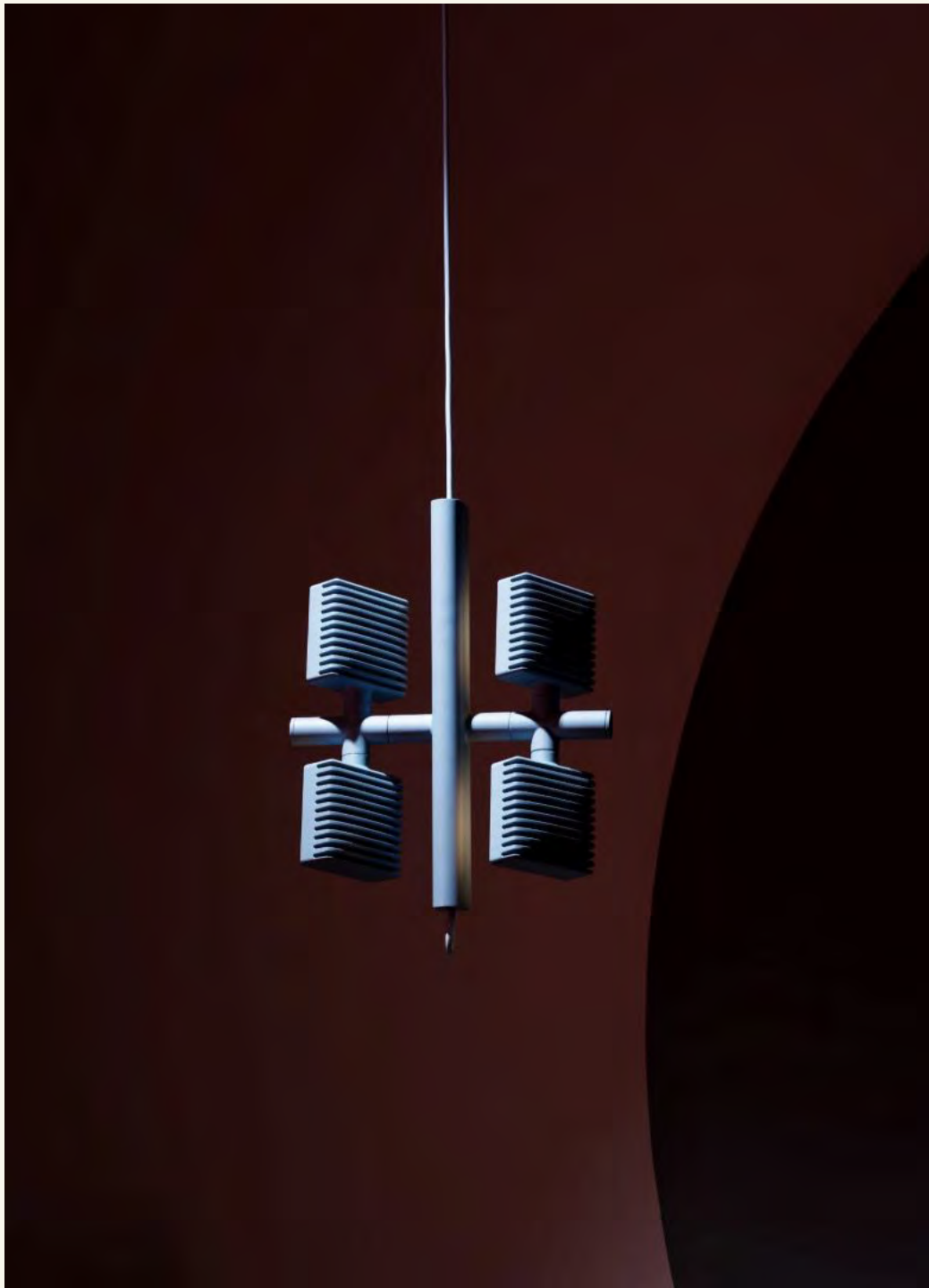











Tiramisu, Montréal









Mile Collection

A collaboration between Lambert & Fils and Guillaume Sasseville, the Mile Collection offers a variation on the linear suspension, pared down to its simplest, asymmetrical expression.

A play on contrasts, the Mile collection is part art installation and part utilitarian light. The use of novel design technologies add to the weightless, almost levitating feel of the lamp.





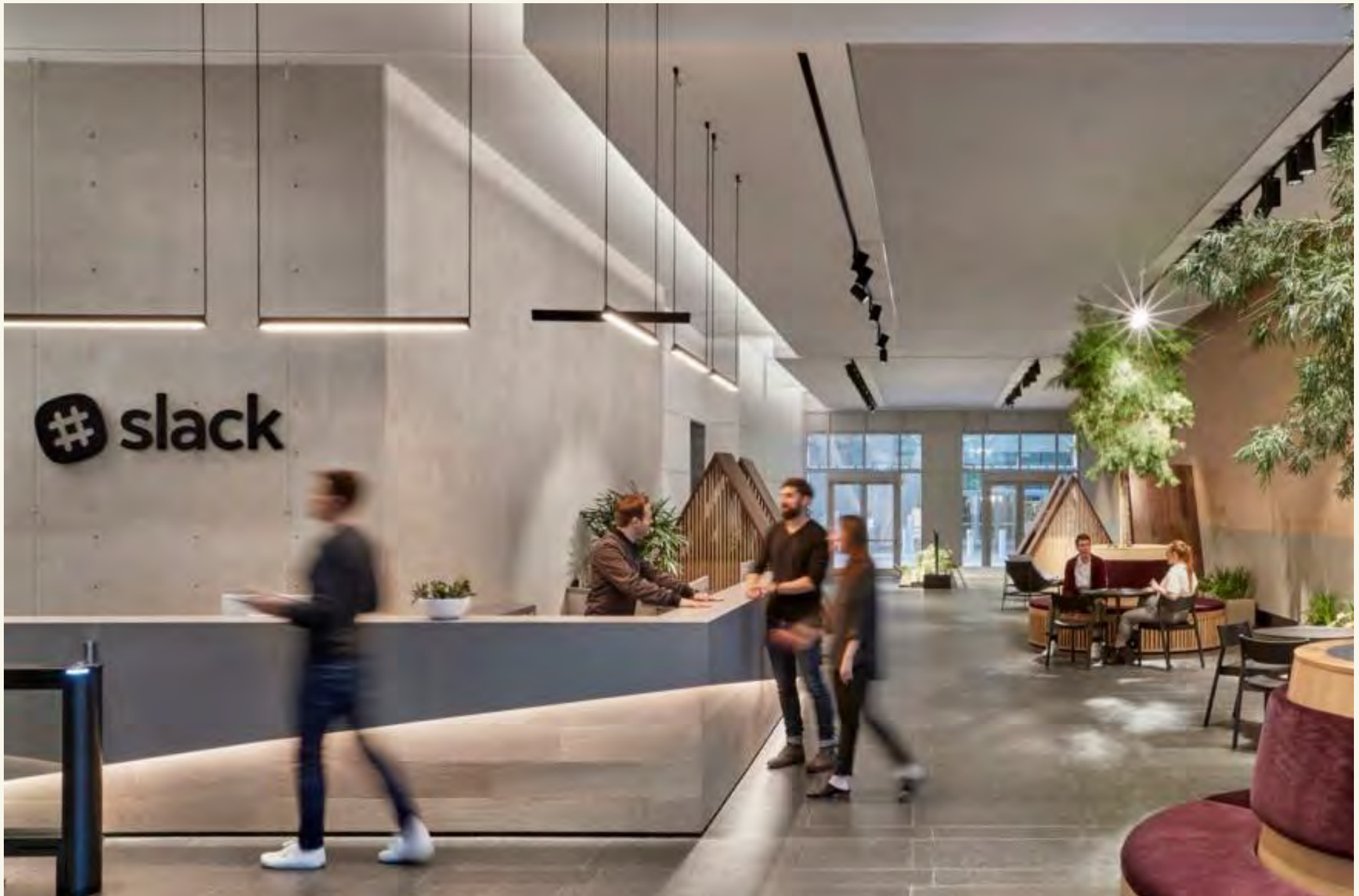

Slack Headquarters, San Francisco, California







Laurent Collection



Molteni & C Showroom, New York



The Laurent Collection places the iconic milk globe in repetition, creating an intricate visual dialogue about possibility and play.

A series of thin forms compliment the globes, carving through space, moving between line, surface, and volume. These forms combine in endless patterns, making it possible for an installation of Laurent lamps to inhabit any space with subtlety and quiet strength.

The collection won the Best of Year Award for lighting by Interior Design Magazine, and was named one of the 10 Best Product Designs of 2017 by Azure Magazine.



Eberhart furniture, Copenhagen, Denmark





Laurent extended models



Elle Decoration UK, stylist Hannah Bort



Laurent Atelier 01



The Laurent variation is poetic simplicity at its best. Inspired by the House of Cards game created by Charles and Ray Eames, its playful composition resembles modules piled on top of each other in happenstance.

Reminiscent of a children's mobile, it adds depth and movement to the original nomenclature of the Laurent, thus unfolding its full potential.



Beaubien Collection



The Alex Hotel, Dublin



The Beaubien Collection's strong black lines bend in and out of space, moving effortlessly between simplicity and ornamentation.

The collection's industrial and graphic aesthetic is imbued with a palette of influences, from traditional Chinese screens to the Memphis movement. Each influence strengthens the collection, creating nuance within its timeless character.

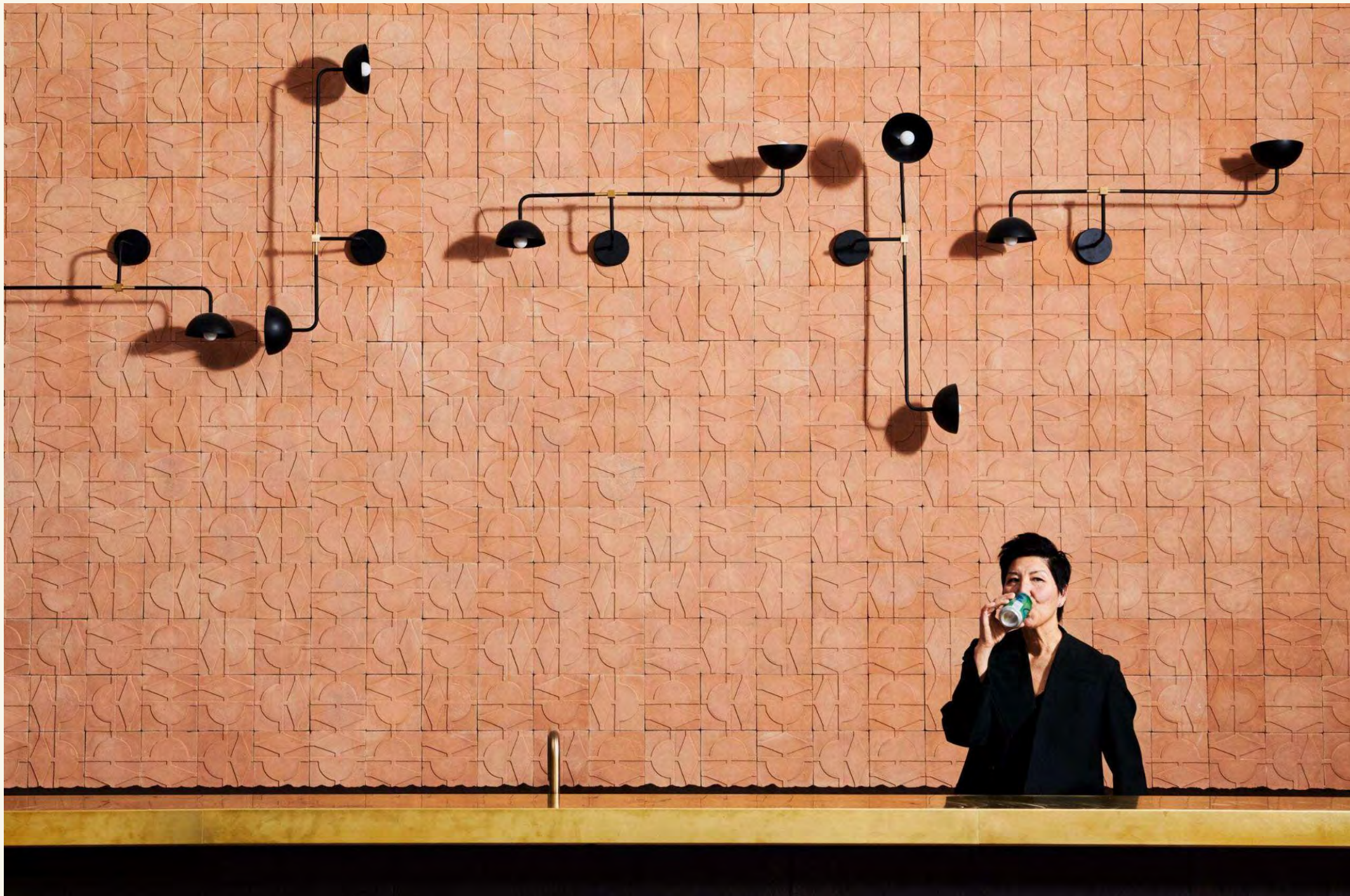

Clé Tile, California

Beaubien Atelier 06



The Beaubien Atelier is a bold, ornamental suspension lamp that adds a maximalist touch to the minimalist spirit of the original collection.

Inspired by the romance of Art Nouveau with a hint of industrial influence, and punctuated by a decorative pattern, the Beaubien Atelier adds a touch of grandeur and opulence to any space.



Beaubien Atelier 01



Guided by images of waterfalls and weeping willows, the Beaubien Atelier 01 provides a focal point that elevates the room it lives in. When viewed from afar, its delicate rose hue seems to change before our very eyes, as if the light itself was warming up; the elusive nature of the Beaubien Atelier 01 creates a dreamlike, meditative atmosphere, at once both comforting and striking.

Dot Collection

The Dot Collection combines the directness of exposed, spherical bulbs with the rich materiality of brass.

Focused, geometric compositions of the collection contain both features, balancing line, surface, and luminous points. The result is a collection of lamps based in the reflectivity of brass—lamps that are both atmospheric and firm.

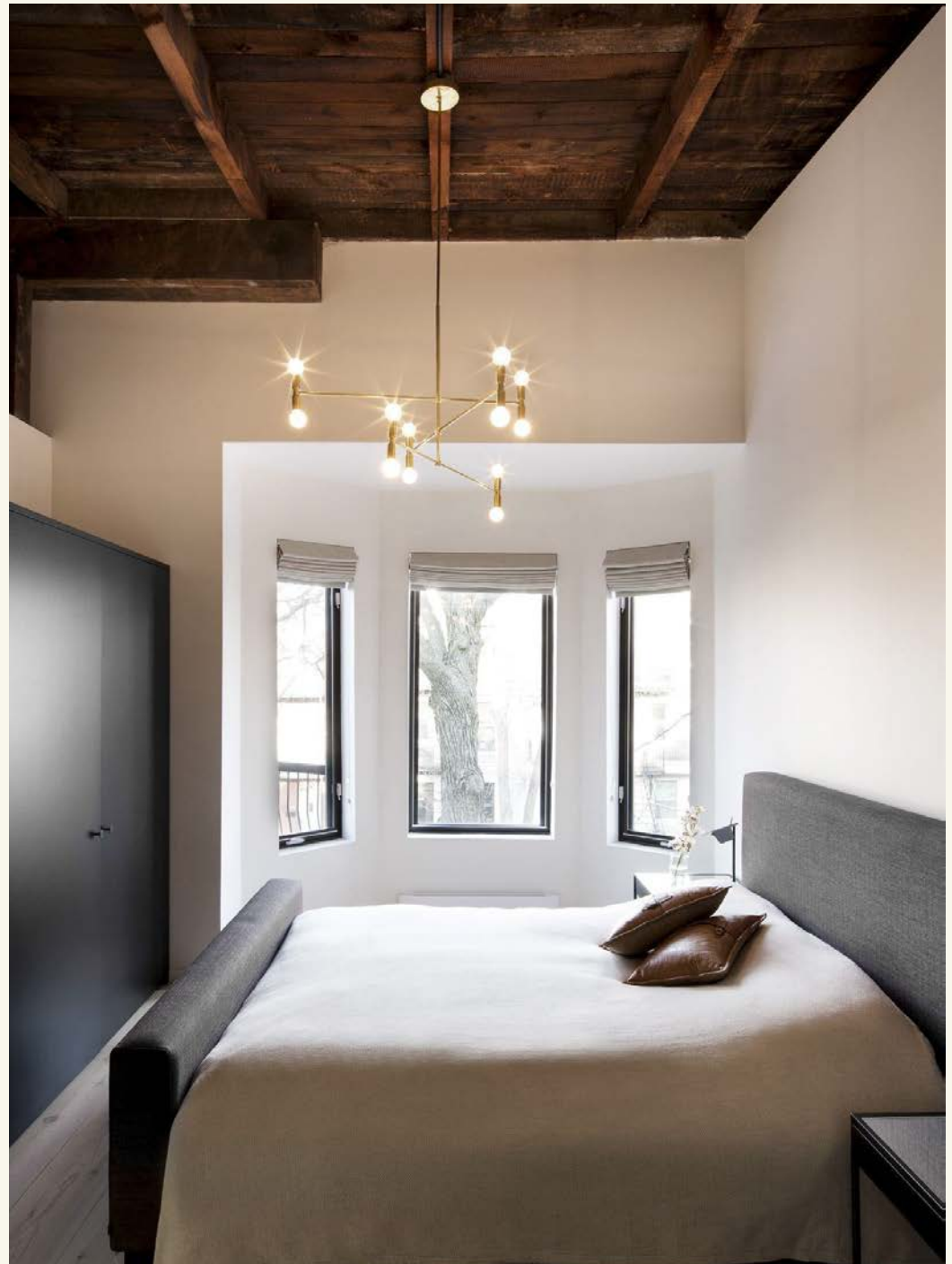

Living Divani Catalogue, by Elisa Ossino Studio



Dot Collection





Kinfolk Office, Copenhagen

Waldorf Collection



Molteni & C, New York

The Waldorf Collection combines an open hemi-spherical shade with a cylindrical socket cover.

This composite shade is deployed in suspension and wall-mounted configurations with natural brass and powder coated rods. Swivelling shades and other moving parts add functional flexibility to the crisp, streamlined forms of this collection.



Kinfolk Office, Copenhagen



Waldorf Collection

Resources

lambert&fils



Laurent 03

The Laurent Collection distills the milk globe to its essential relationship between circle and sphere. A series of thin forms compliment the Laurent globes –forms that combine in endless patterns and carve through space.

Position [▼](#)

Finish / Cord [▼](#)

Canopy [▼](#)

Get a Quote

Details [▼](#)

Downloads [▼](#)

Customization [▼](#)

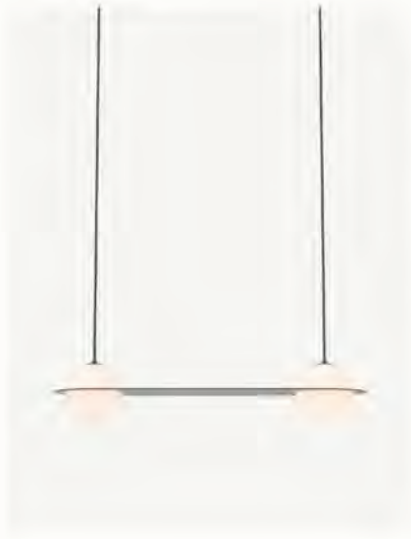

LAURENT 03

The Laurent Collection distills the milk globe to its essential relationship between circle and sphere. A series of thin forms compliment the Laurent globes—forms that carve through space, moving between line, surface, and volume. These forms combine in endless patterns, making it possible for an installation of Laurent lamps to inhabit any space with subtlety and quiet strength.

- type:** suspension
- construction:** polished brass, powder coated aluminium or nickel plated steel frame
handblown opaline glass globe
powder coated aluminium or brass hardware
polyester cord
- specifications:** source: LED lamp provided (G9 base)
power consumption: 2x 4,5W
lumen output: 638lm
colour temperature: 2700K included
* 3000K available upon request
colour rendering index: 80 CRI standard
* ≥ 90 CRI upon request
expected lifetime: 25 000h
- control:** refer to our recommended list of dimmer models
- cord length:** 84" / 213 cm (minimum 30" / 76 cm for angled wires)
- weight:** parallel- brass/nickel plated: 12.1 lb / 5.5 kg
aluminium: 9.1 lb / 4.1 kg
angled- brass/nickel plated: 10.3 lb / 4.7 kg
aluminium: 7.3 lb / 3.3 kg
- certifications:** IP20
- warranty:** 2 years

Description

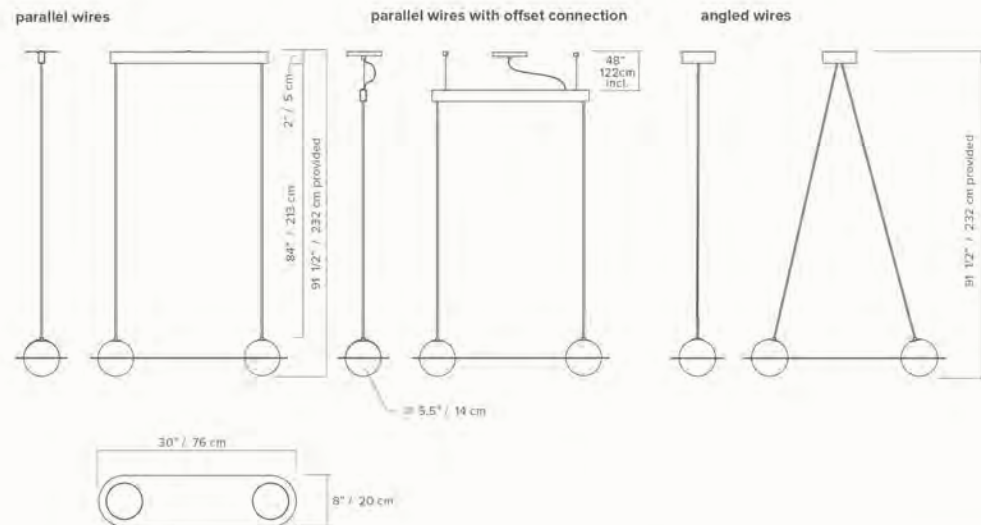

Dimensions

*dimensions are approximate and may vary slightly

ORDER GUIDE: SKU

COLLECTION	MODEL	MOUNTING POSITION	FRAME	CORD SYSTEM	CANOPY	
LRT	Laurent	03	AW angled wires PW parallel wires <small>*please specify if offset or standard (ceiling disc) and colour</small>	BK black BR brass BE blue BU burgundy CH nickel plated TU turquoise	BK black BR brass BE blue BU burgundy BG beige	BK black BE blue BU burgundy WH white BG beige TU turquoise
LRT	03	AW	BK	BK	BK = LRT03AWBKBBK <small>example</small>	

Order Guide

FRAME



CORD SYSTEM FINISH
globe holders & cords



CANOPY

*black/white or same colour as cord system except for turquoise



MOUNTING TYPE SYSTEM

ceiling disc or offset canopy with anchors
*black/white or same colour as canopy

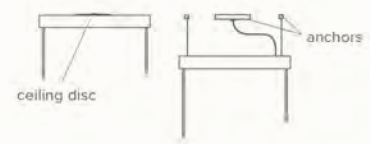
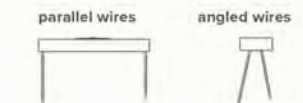
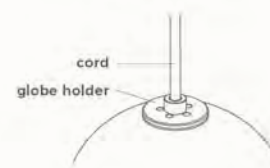
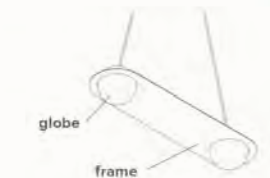

Colour & Options

DIMMER SPECIFICATIONS

DIMMER LIST COMPATIBILITY FOR G9 LED BULBS – 120V

The dimming technology offering the best results is ELV (electronic low voltage) dimmers with reverse phase or trailing edge control.

DIMMER BRAND	MODEL NUMBER	MIN LEVEL	MAX LEVEL	FLICKERING	OVERALL QUOTE
LUTRON - MAESTRO	MAELV-600	0%	100%	0%-10%	good
LUTRON - SKYLARK	SELV-300P	0%	100%	no	very good
LUTRON - SKYLARK	SELV-303P	0%	100%	no	very good
LUTRON - SKYLARK	CTELV-303P	0%	100%	no	very good
LUTRON - DIVA	DVELV-300P	0%	100%	no	very good
LEGRAND - ADORNE	TRUE UNIVERSAL	30%	100%	no	good

DIMMER LIST COMPATIBILITY FOR G9 LED BULBS – 230V

DIMMER BRAND	MODEL NUMBER	MIN LEVEL	MAX LEVEL	FLICKERING	OVERALL QUOTE
VARILIGHT	V-PRO	2%	100%	no	very good
LEGRAND - NILOÉ	3 996 35	15%	87%	no	good
NIKO	310-0280X	5%	94%	no	very good
NIKO	310-0190X	1%	100%	no	very good

*Other dimmers can yield good results and we recommend conducting your own test before final installation

EU ENERGY LABEL

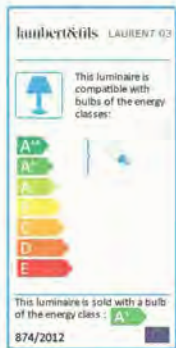

NOTES:

- must be installed by an electrician
- not protected against liquids (refer to IP20)
- additional charges for modifications or for special orders
- please refer to maintenance sheet on website for cleaning instructions

Updated: Jan 2020

Recommended Dimmers

Energy Label

lambert&fils

Filtering options



Material Library

Filter by Type
Cords , Glass , Metal

Filter by Collection
Sainte - Classic , Sainte - Atelier , Parc ,
Hutchison , Dorval , Mile , Laurent , Clark ,
Beaubien , Cliff , Dot , Waldorf

Finishes

